

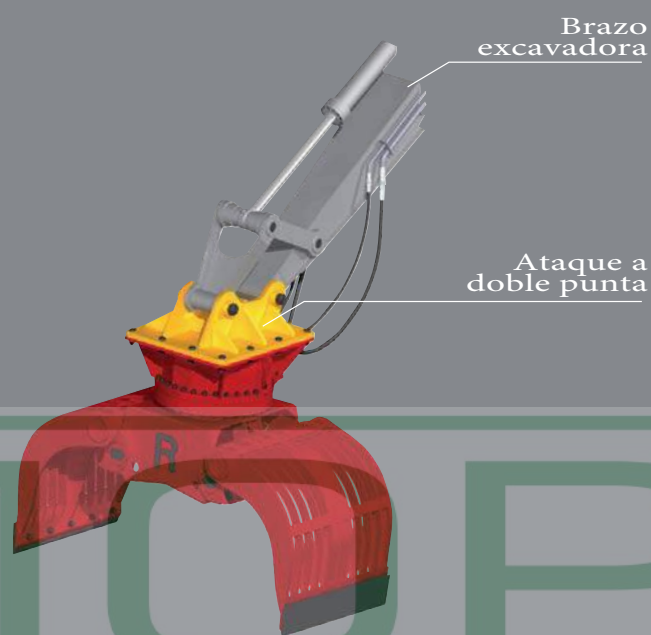

CATÁLOGO COMPLETO DE PINZAS

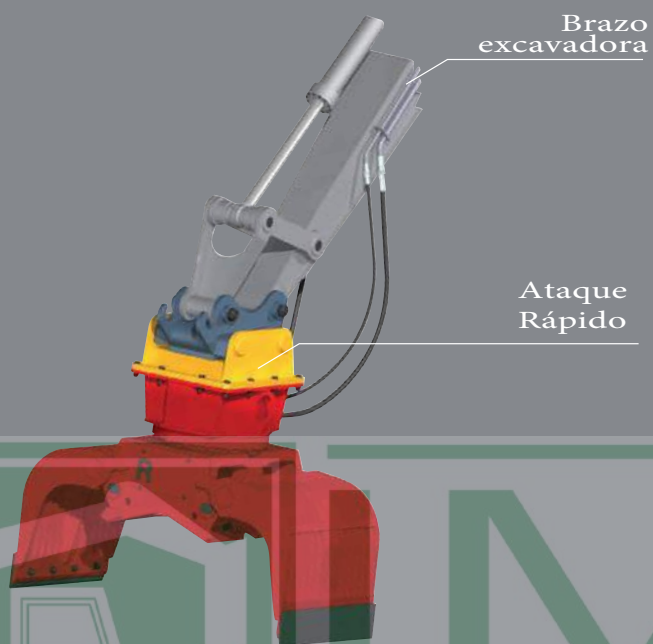

GRUPO IMOP



www.imopsl.com

Esquema de uso para pinzas de demolición y selección

Pinza	Peso excavadora
RS100 (R605 / R104X)	1,5 - 4
RS195 - RS200 (R606)	3 - 6
RSG300F	6 - 12
RSG400F - RSG450F	10 - 15
RS500	13 - 20
RS600	14 - 20
RS800	19 - 25
RS1000	22 - 32
RS1150	24 - 32
RS1300	26 - 32

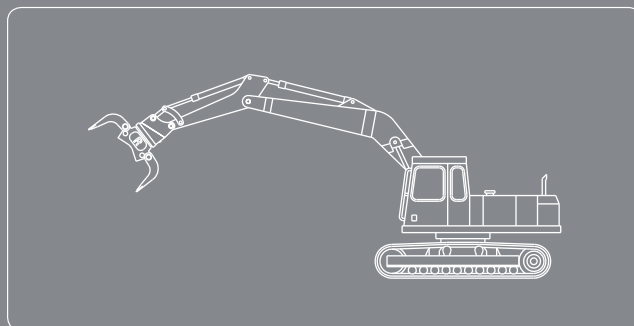

> RS100

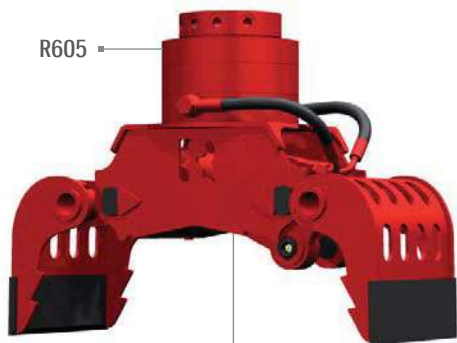

R605

> RS195

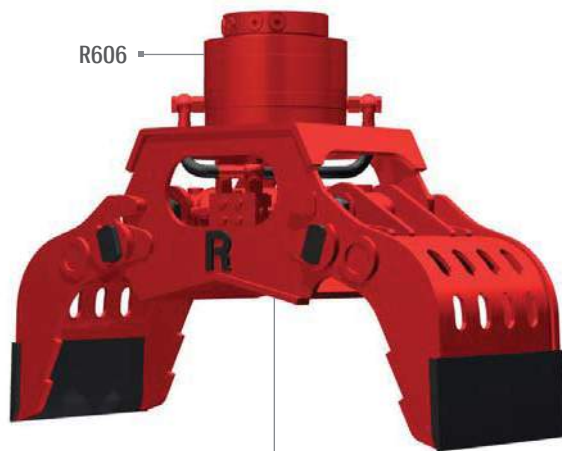

R606

> RS100

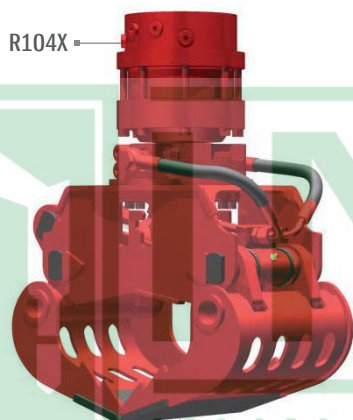

R104X

> RS200F

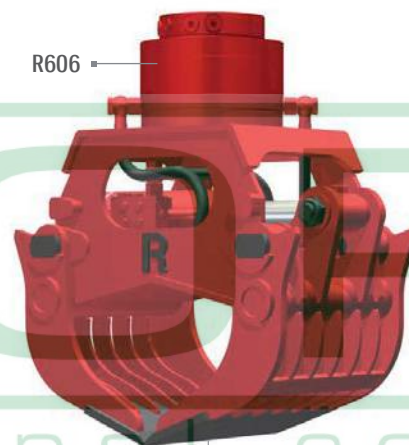

R606

www.imopsl.com

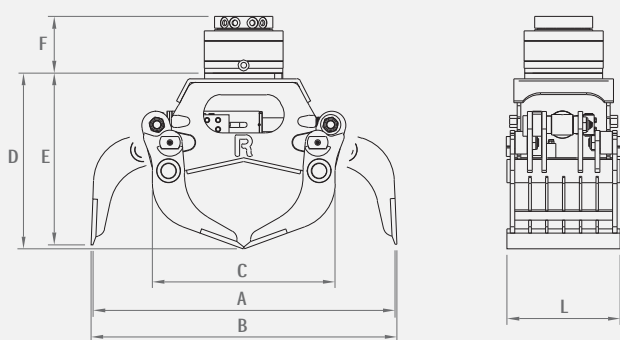

Modelo	Peso	Dimensiones
	kg	F
R104X	45	270
R605	40	180
R606	55	185

Modelo	Capacid.	Peso	Presión	Aceite	Presión	Aceite	Fuerza	Dimensiones					
	dm ³	kg	bar	l/min	bar	l/min	Kg	A	B	C	D	E	L
RS100	17	70	300	20	250	20	1150	675	700	490	380	360	300
RS195	40	150	300	30	250	20	2320	970	1000	670	600	580	370
RS200F	40	150	300	30	250	20	2320	970	1000	670	600	580	370

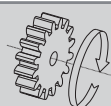

> RSG300F



> RSG400 > RSG450

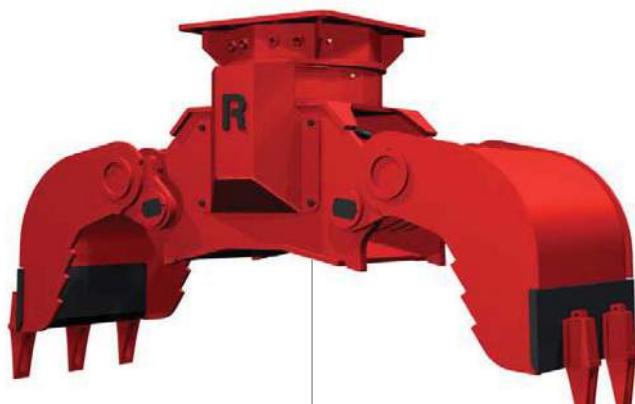

> RSG300



> RSG400F > RSG450F

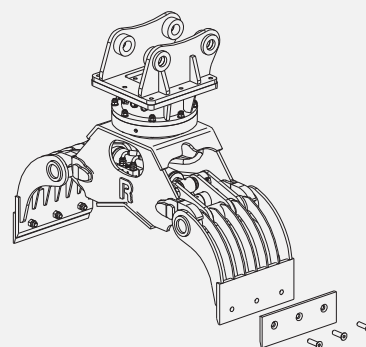
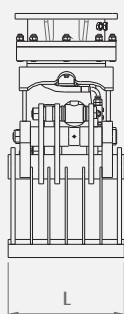
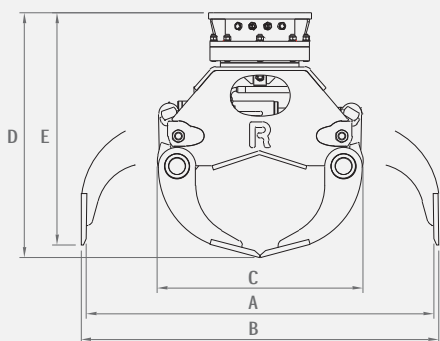

Modelo	Capacid. Peso		Presión	Aceite	Presión	Aceite	Fuerza	Dimensiones					
	dm ³	kg						bar	l/min	bar	l/min	Kg	A
RSG300F	100	390	300	50	250	30	2500	1350	1400	800	950	900	450
RSG400F	220	750	300	60	150	30	3300	1800	1840	1110	1180	960	600
RSG450F	260	780	300	60	150	30	3300	1800	1840	1110	1180	960	700

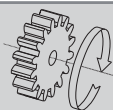
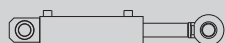

> RS500 > RS600

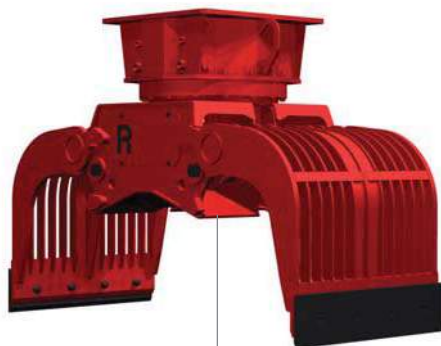

> RS800



> RS500 > RS600

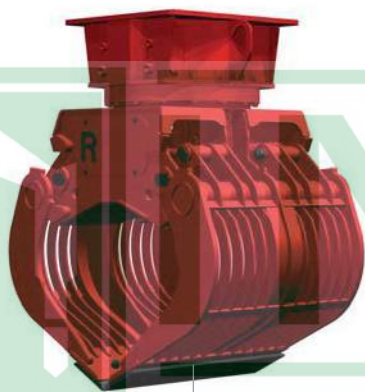

> RS800

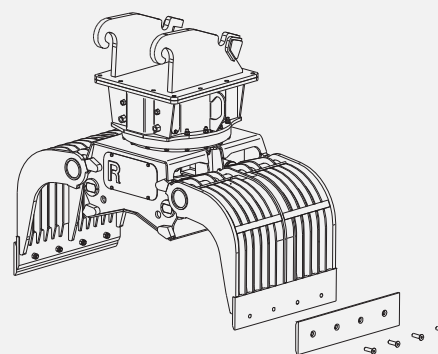
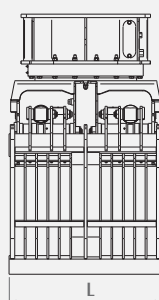
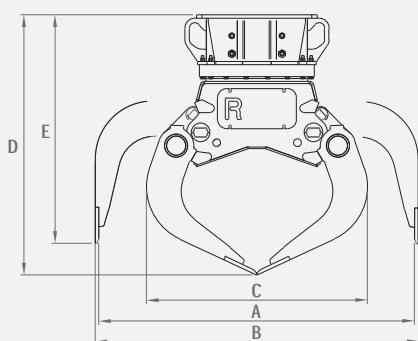

Modelo	Capacid. Peso		Presión	Aceite	Presión	Aceite	Fuerza	Dimensiones					
	dm ³	kg						bar	l/min	bar	l/min	Kg	A
RS500	500	990	320	80	170	30	4100	1760	1800	1230	1400	1230	850
RS600	600	1050	320	80	170	30	4100	1760	1800	1230	1400	1230	1000
RS800	800	1500	320	120	170	30	5600	2000	2060	1360	1620	1440	1000



> RS1000 > RS1150 > RS1300

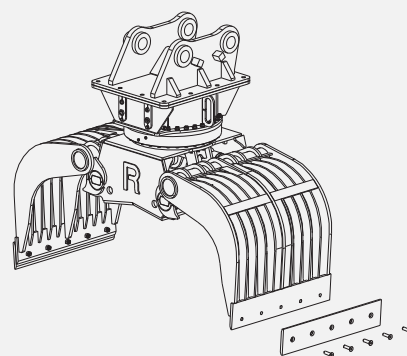
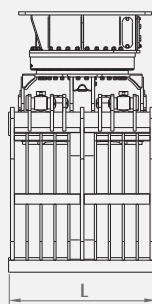
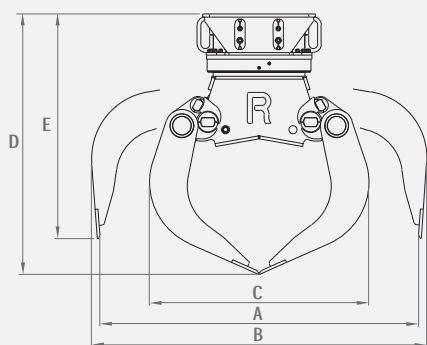

Modelo	Capacid. Peso		Presión bar	Aceite l/min	Presión bar	Aceite l/min	Fuerza Kg	Dimensiones					
	dm ³	kg						A	B	C	D	E	L
RS1000	1000	1690	320	120	170	30	5050	2200	2280	1490	1740	1490	1000
RS1150	1150	1770	320	120	170	30	5050	2200	2280	1490	1740	1490	1150
RS1300	1300	1850	320	120	170	30	5050	2200	2280	1490	1740	1490	1300

